

1 New actuators for aerospace

C. Mangeot¹, B. Andersen¹ and R. Hilditch²

¹Noliac Motion, Hejreskovvej 18, Kvistgaard, 3470, Denmark

²AgustaWestland, part of the Finmeccanica Group, Lysander Road, Yeovil, BA20 2YB, United Kingdom

2 Abstract

The field of active rotor control through the use of trailing edge flaps has been widely covered in the literature. Although the benefits (reduction of the vibration levels by up to 80%) are well recognised, up to now no application has reached commercial success. In the UK Technology Strategy Board (TSB) funded REACT project, Noliac Motion and Anglo-Italian helicopter company AgustaWestland, part of the Finmeccanica Group, team-up to provide a more effective solution.

After a study of the literature, a new actuator design was developed, providing improved performance for a minimum mass. Prototypes have been manufactured and tested and a patent applied for.

3 Introduction

The field of active control of helicopter rotor blade has raised a consequent interest in the last 20 years. The research effort has been supported by several national and international programs both in the USA and in Europe.

The reason for this interest is the expected benefits of this technology. With an expected 80% vibration reduction and a 10dB noise reduction^[8], this technology will give rotorcrafts a tremendous advantage both in civil and military applications. In addition, active control is also expected to improve rotor aerodynamics, therefore enlarging the flight envelope and reducing power consumption.

Because of the high operating frequency, smart materials such as piezoelectric actuators are well adapted for this task. The relatively large displacements (in the sub-millimetre to millimetre range) require some sort of mechanical amplification of the movement.

Moreover, the field of aerospace implies specific and very demanding requirements. In particular, a special attention is given to the mass of the equipment. In addition, the wide temperature range, large accelerations and high vibration levels are demanding requirements that need to be taken into account for the design of an active device. The design has to fulfil all the requirements while optimising the mass.

The issue of the temperature range has rarely been addressed in publications. It is however a concern, since differential thermal expansion between the piezoelectric ceramic, the metallic components of the amplifying system and the composite material of the rotor blade will inevitably cause an apparent and unwanted movement of the actuator.

Previous publications have focussed on the “efficiency” of active devices, sometimes with a different definition. A paper^[3] points out the difference between mechanical efficiency (the ratio between available energy and active element energy) and mass efficiency (mechanical efficiency multiplied by the ratio between active mass and total mass).

Although it might be more relevant than the mechanical efficiency, this definition can be misleading. In this paper, the focus is placed directly on the energy density, i.e. the ratio between available energy and mass of the device.

4 State of the art

4.1 Review of publications

A number of publications can be found on the topic of active rotor control.

Some reviews^[1, 2, 3] list a number of concepts. Some of them (blade twist, active blade tip) are not relevant for this search. Rotor blade flap technologies are analysed specifically and several concepts can be listed:

- Bender concept, developed from 1989 (Boeing CH-47D)
- “V” stacks (magnetostrictive) 1993
- Bender and tapered bender from 1994 (MIT)
- Extension-torsion mechanism 1995
- Hydraulic amplification 1995
- X-Frame design, from 1997 (Boeing CH-47D)
- L-L amplification concept (double lever amplification), from 1999
- Double X-frame concept, from 2000
- Amplified stack 1998 (EADS)

In addition, different electromagnetic actuation systems are described. They won’t be addressed in this paper.

4.2 Analysis of the state of the art

The actuator concepts described in the literature can be classified in different families.

- Triangle amplification

In the triangle amplification, the mechanical advantage is given by a small angle between two active elements. An actuator was devised^[4], using two magnetostrictive elements. This actuator provides very high energy levels. It is however rather heavy because of the material and coils needed for the magnetostriction.

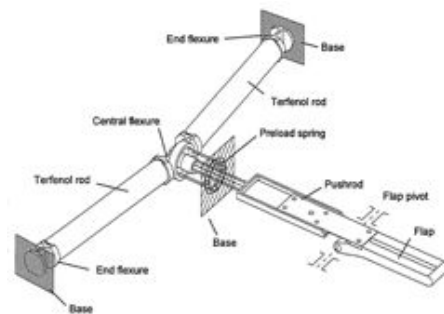

Figure 1 Bushko-Fenn V-stacks (magnetostrictive)

- X-Frame

The X-frame is documented by regular publications^[5, 6].

The design is based on two piezoelectric actuators enclosed in a metallic structure. Actuation of the active elements induces a “scissors”-like movement of the frames. The design was optimised for “mass efficiency”.

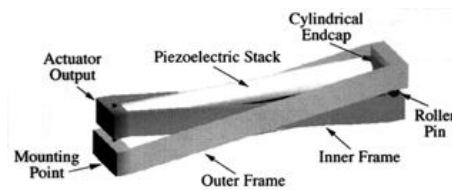

Figure 2 Precht-Hall X-Frame

- Double X-Frame

The double X-frame^[7, 8] was developed as a direct continuation of the X-frame, in order to increase the available power. This principle was applied to Boeing’s SMART active flap rotor.

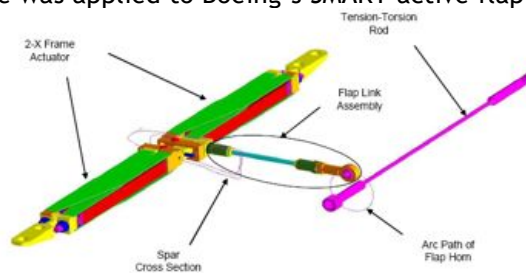

Figure 3 Straub-Kennedy Double X-Frame

Although the available energy increased compared to the X-frame, the additional parts and non-optimal kinematics (the two actuators can be pulling the fixtures and fighting each other) had an adverse effect on the energy density.

- L-L amplification

A two-stage amplification mechanism was also disclosed^[9], providing large stroke ($\pm 0,76$ mm). However the force capability is not stated and is expected to be relatively low as it is often the case for double amplification systems.

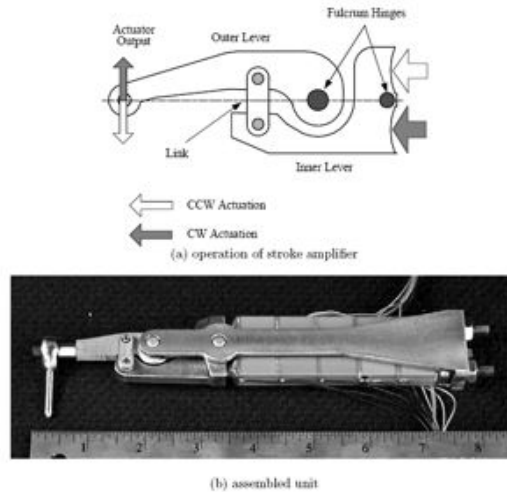

Figure 4 Lee-Chopra Differential stacks with L-L amplification

It should be mentioned that this system is based on two actuators in differential mode, therefore more temperature stable than previous concepts.

- Flextensional actuators (CEDRAT)

Flextensional actuators are commercially available from several vendors, such as CEDRAT^[14], and have been used for research in active trailing edge applications.

These actuators provide a high stiffness and relatively large displacements. On the other hand, their mass is not optimised and the metallic shell implies a large penalty on the mass.



Figure 5 CEDRAT APA 1000XL Amplified stack

- Composite flextensional actuators (ONERA)

Researches are running, in particular at the ONERA^[10, 11, 12], in order to improve the mass of these flextensional actuators by using a composite instead of metal for the frame.

Unfortunately, the development is apparently causing important technical issues and no performance data is disclosed in the publications.



Figure 6 Petitniot Carbon APA frame

- Articulated frame

Another form of mechanical amplification which has reached commercial success is through the use of a deformable frame where the strain is concentrated at specific hinge points. This type of product is available for example from the company DSM^[13].

Although the mechanical efficiency of these devices is higher than flextensional actuators, their weight is still impacted by a rather bulky metallic structure.



Figure 7 DSM FPA-2000E Amplified stack

- Optimised articulated frame
EADS^[2, 15] has also developed a specific amplification frame for trailing edge application. This frame addresses some of the issues implied by the aerospace application, such as centrifugal loads. It has also been optimised for mass.

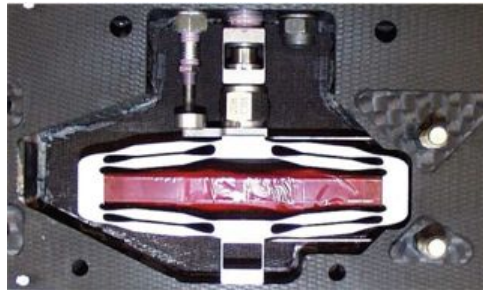

Figure 8 Jänker Amplified stack

4.3 Comparison

When data has been published, the different concepts can be compared according to the energy density criterion defined above. Table 1 gives the collected data and the data is plotted on Figure 12. Energy (W) is calculated at the most advantageous operating point, i.e. half the free displacement (d_F) and half the blocking force (F_b), assuming linear stiffness. In other terms:

$$W = \frac{1}{8} \cdot d_F \cdot F_b$$

Developer	Product	Energy (N.m)	Energy density (N.mm/g)	Ref.
CEDRAT	APA 1000 L	46,6	0,25	[14]
CEDRAT	APA 1000 XL	97,8	0,16	[14]
DSM	FPA 1450 C	54,4	0,25	[13]
DSM	FPA 2000 E (Ti)	36,3	0,21	[13]
MIT	X-frame	41,0	0,34	[6]
MIT	Double X-Frame	129,3	0,13	[8]
EADS	RACT actuator	175,0	0,39	[2,

SatCon	V stacks MS	236,3	0,08	[4]
--------	----------------	-------	------	-----

Table 1 Energy density comparison

It can be seen that all the points are below 0,4 N.mm/g. Furthermore, energy density tends to decrease for high energy levels.

5 New design

A new design was developed to address the limitations in terms of energy density and temperature stability.

It is based on four piezoelectric stacks, connected in pairs. Each stack is hinged at its ends and maintained in place with a small angle. The arrangement is shown on Figure 9.

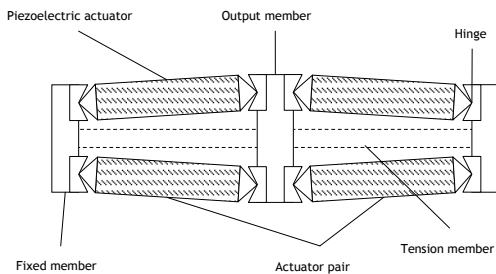

Figure 9 "Diamond frame" principle

The whole assembly is preloaded through the use of a tension member maintaining the fixed members in place. This ensures that the piezoelectric stacks operate in optimal conditions.

The actuator is operated as follows. When the applied voltage is increased on one pair of stacks, it is decreased on the other pair. This contributes to a movement of the output member in one direction. It should be noted that in the case of a free displacement, the tension in the piezoelectric stacks as well as in the tension members (therefore the preload) remains almost constant.

Upon temperature change, differential thermal expansion between the ceramic and the other materials in the assembly will lead to a change in force repartition. This will result in a change in the internal preload. However unlike most of the existing schemes presented above, this will not result in a movement of the output member.

Thanks to the compact design and the large proportion of active material, this design was expected to provide high performance levels as well as high energy density.

6 Prototype and test results

6.1 Prototype

A prototype was designed to assess the performance of this layout. The design is based on custom-designed piezoelectric actuators manufactured by Noliac. The mechanical parts were manufactured such that they would allow some flexibility for the assembly and testing. The mobility of the stacks is ensured by rolling contacts.

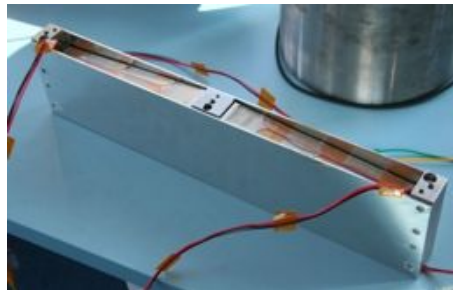

Figure 10 "Diamond frame" prototype

The characteristics of the piezoelectric stacks are given in Table 2.

Property	Unit	Value
Material	-	PCM51
Cross-section	mm x	24,6 x
	m	2
	m	4,6
		6

Height	mm	163,5
Operating field	kV/mm	0 to +3,0
Free displacement	μm	245
Blocking force	N	25400

Table 2 Piezoelectric stacks properties

In order to evaluate the performance of the actuator, a test was performed using a materials testing machine (INSTRON 6025 with external displacement sensor). The stiffness of the actuator was measured at middle position and in the extreme positions. Figure 11 gives the results of the test for middle position and fully extended.

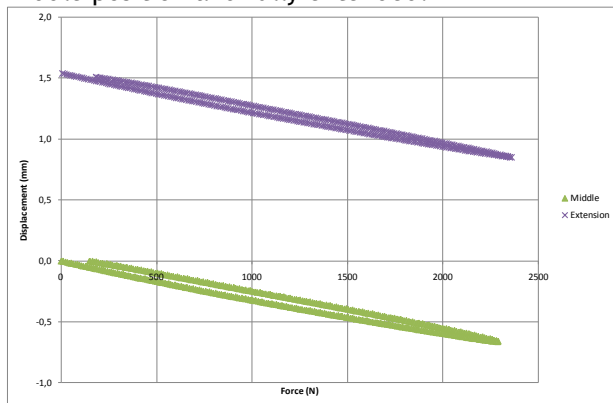

Figure 11 "Diamond frame" prototype force-displacement diagram

It should be noted that on this graph the free displacement is over evaluated because of the contribution of the creep effect over the duration of the experiment (several minutes). The actual free displacement given below was measured in quasi-dynamic mode (0,1Hz) to reduce this effect. As it can be seen, stiffness is very consistent (<5% difference between middle and extreme positions). From these measurements and additional performance measurements in Noliac, the performance of the amplified actuator can be expressed in Table 3. Blocking force is estimated by multiplying the measured large signal stiffness with the measured free displacement.

Property	Unit	Value
Free displacement	μm	± 1370
Blocking force	N	± 4460
Mass	g	5800

Table 3 Amplified actuator properties

This represents an energy density of 0,53 N.mm/g.

6.2 Comparison with the state of the art

The performance of the "Diamond frame" Piezoelectric Actuator (DPA) can be compared to the state of the art on a graph showing the energy density versus the total available energy (Figure 12).

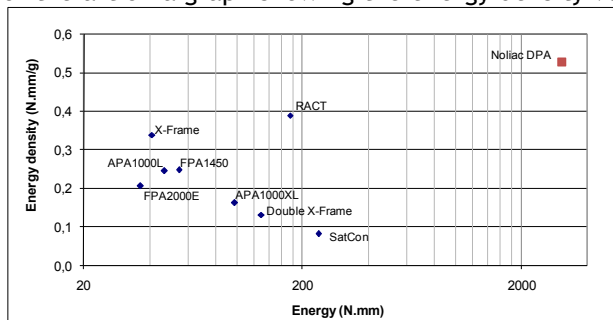

Figure 12 Energy density comparison

It is obvious from this graph that the "Diamond frame" prototype was designed for much higher energy levels than previously published literature. It is also clear that it demonstrates a significant improvement in terms of energy density (+35%).

7 Future work

It is believed that the energy density of the DPA can be further improved.

In particular, this first prototype was built with readily available materials, mostly steel. Thanks to their simple shape, most of the mechanical parts can be manufactured using lightweight materials. In particular, the side panels are well suited for fabrication in carbon fibre. It is estimated that this change would bring the energy density to 0,6 N.mm/g, a 50%+ improvement compared to the state of the art.

Another part of the further work will be to integrate the DPA in the Active Trailing Edge application. This includes the design of mechanical interfaces and an appropriate driver.

In addition, Noliac will adapt the design to other applications and demonstrate the benefits on a range of products.

8 Conclusions

Although the field of active rotor control has been widely covered in the literature, no application has reached commercial success. The main reasons are the mass penalty implied by the actuators and the issue of temperature stability.

In the UK Technology Strategy Board (TSB) funded REACT project, Noliac and Anglo-Italian helicopter company AgustaWestland, part of the Finmeccanica Group, team-up to provide a more effective solution. This research has led to the design of a new type of amplified actuator that is the subject of a joint patent application, called "Diamond frame" Piezoelectric Actuator (DPA).

A prototype has been manufactured and tested. It demonstrates a 35% increase in energy density compared to the literature. In other words the actuator would be capable of the same performance for 74% of the mass of the best existing solution. It is thought that this figure can be further improved through the use of lightweight materials.

9 References

- [1] "Review of Smart-Materials Actuation Solutions for Aeroelastic and Vibration Control", Victor Giurgiutiu, University of South Carolina, Journal of intelligent material systems and structures, Vol. 11–July 2000
- [2] "New Actuators for Aircraft and Space Applications", P. Jänker, F. Claeysen..., EADS / CEDRAT TECHNOLOGIES, ACTUATOR 2008
- [3] "Design of a high efficiency, large stroke, electromechanical actuator" Eric F Prechtel and Steven R Hall, Massachusetts Institute of Technology, in Smart Materials and Structures 8 (1999) 13-30
- [4] "Integrated actuation system for individual control of helicopter rotor blades", Dariusz Bushko, Ralph Fenn, Mike Gerver, John Berry, Frank Philips, SatCon Technology Corp., 1996
- [5] "Preliminary Testing of a Mach-Scaled Active Rotor Blade with a Trailing Edge Servo-Flap", Steven R. Hall and Eric F. Prechtel, Massachusetts Institute of Technology, in Smart Structures and Materials 1999: Smart Structures and Integrated Systems, pp.14-21
- [6] "Design of a high efficiency, large stroke, electromechanical actuator" Eric F Prechtel and Steven R Hall, Massachusetts Institute of Technology, in Smart Mater. Struct. 8 (1999) pp.13-30
- [7] "Design and testing of a double X-frame piezoelectric actuator", Steven R. Hall, Theodora Tzianetopoulou, Massachusetts Institute of Technology, in Smart Structures and Materials 2000: Smart Structures and Integrated Systems, pp.26-37
- [8] "Development and whirl tower test of the SMART active flap rotor", Friedrich K. Straub, Dennis K. Kennedy, Alan D. Stemple, V.R. Anand, and Terry S. Birchette, Boeing, Smart Structures and Materials 2004: Industrial and Commercial Applications of Smart Structures Technologies
- [9] "Design of a Bidirectional Piezoelectric Actuator for Blade Trailing-Edge Flap", Taeh Lee and Inderjit Chopra, University of Maryland, Smart Structures and Materials 2001: Smart Structures and Integrated Systems
- [10] "Experimental assessment and further development of amplified piezo actuators for active flap devices", J-L. Petitniot, H-M. des Rochettes, P. Leconte, ONERA, ACTUATOR 2002
- [11] "Experimental assessment of an active flap device", MERCIER des ROCHETTES Hugues, LECONTE Philippe, AHS 58th annual forum and technology display, 2002
- [12] "APA's and Derived Shaped Actuators Using Composite Shells and Offering Higher Performances for Aeronautical Purposes", J-L. Petitniot, ONERA, ACTUATOR 2008
- [13] DSM website <http://www.dynamic-structures.com/>
- [14] CEDRAT website <http://www.cedrat.com/>
- [15] "Advanced piezoelectric servo flap system for rotor active control", P. Jänker, F. Hermle, S. Friedl, K. Lentner, B. Enenkl, C. Müller, 2006

